

Ultra Low Capacitance TVS Array

- REVISION 1 -

INTRODUCTION

DESCRIPTION

The MN2.8-4 is ultra low capacitance TVS array, which provide 600W peak pulse protection for unidirectional or bidirectional lines either in common mode or differential mode.

Low capacitance in both directions provides more stable working for high frequency applications at application voltages below 2.8V.

The MN2.8-4 array is designed for using in applications where the protection against electrostatic discharge (ESD) as described in IEC61000-4-2, electrical fast transient (EFT) as described in IEC61000-4-4 and second level effects of lightning are required.

APPLICATIONS

- Interfaces
- Ethernet 10/100
- RS232/RS422
- Cellular phones
- Audio/Video entry
- Personal Digital Assistance (PDA)

PHYSICAL CHARACTERISTICS

- SO-8 Surface mount package
- Weight 0.6 grams (approximate)
- Marking: Logo, Device code, Date code
- 12 mm Type and Reel

FEATURES

- Standards IEC 61000-4-2 and IEC64000-4-4
- 600W Peak Pulse Power per line (8/20 μ s)
- Protect two bidirectional lines or two differential line pairs
- Low operating voltage: 2.8V
- ESD Protection > +/-30kV
- Low bidirectional capacitance <5pF
- Low leakage current < 1 μ A

ELECTRICAL SCHEMATIC

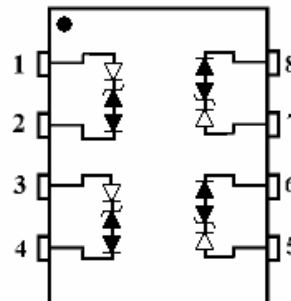

MECHANICAL CHARACTERISTICS

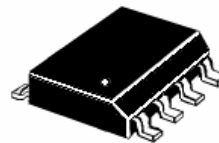

ORDERING INFORMATION

MN0284"T"- "P"-TR

"T" for temperature= "C" for commercial (0 - 70°C) or "I" for industrial (-20°C - +85°C) - Default or no indication means "C"

"P" for packaging= "D" for DIP, "SO" for SOIC
"TR" for Tape and Reel - No indication means delivery in tube (for SOIC only)

ASOLUTE MAXIMUM RATINGS

Rating	Symbol	Value	Unit
Peak Pulse Power ($\tau_P = 8/20 \mu s$)	P_{PP}	500	W
Peak Pulse Current ($\tau_P = 8/20 \mu s$)	I_{PP}	30	A
Operating Temperature	T_{stg}	-55 to +150	°C
Storage Temperature	T_J	-55 to +125	°C

Stresses exceeding Maximum Ratings may damage the device. Maximum Ratings are stress ratings only. Functional operation above the Recommended Operating Conditions is not implied. Extended exposure to stresses above the Recommended Operating Conditions may affect device reliability.

MN4230 ELECTRICAL CHARACTERISTICS

($T_A = 25^\circ C$ unless otherwise noted)

STAND OFF VOLTAGE V_{WM} VOLTS (See Note 1)	BREAKDOWN VOLTAGE V_{BR} @ $I=1mA$ VOLTS MIN (See Note 1)	SNAP-BACK VOLTAGE V_{SB} @ $I_{SB}=50mA$ VOLTS MIN (See Note 1)	CLAMPING VOLTAGE V_C @ $I_{PP}=2A$ VOLTS MAX (See Note 1) (See Fig.1)	CLAMPING VOLTAGE V_C @ $I_{PP}=5A$ VOLTS MAX (See Note 1) (See Fig.1)	CLAMPING VOLTAGE V_C @ $I_{PP}=24A$ VOLTS MAX (See Note 1) (See Fig.1)	CLAMPING VOLTAGE V_C @ $I_{PP}=30A$ VOLTS MAX (See Note 1) (See Fig.1)	LEAKAGE CURRENT @ V_{WM} ID μA MAX (See Note 1)	CAPACITANCE C @ 0V, (1 MHz) pF MAX (See Note 1)
2.8	3.0	2.8	5.5	8.5	15	21	1.0	3

Note 1 : Measured between pin1 to pin2, pin3 to pin4, pin5 to pin6 and pin7 to pin8

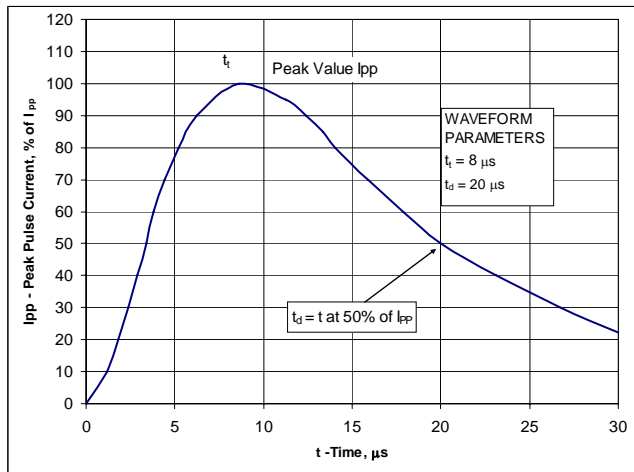

Figure 1. Pulse Wave Form

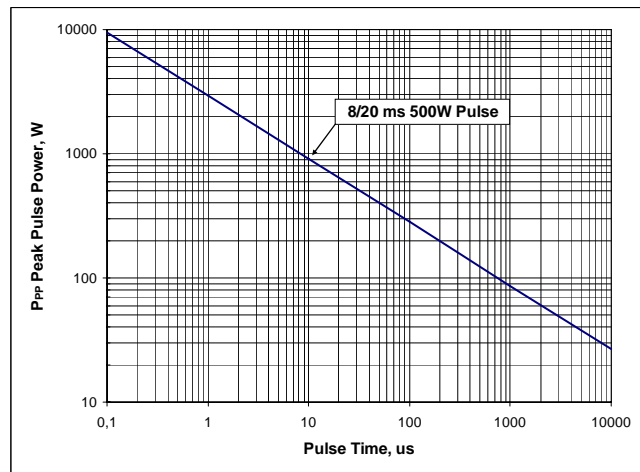

Figure 2. Peak Pulse Power vs Pulse Time

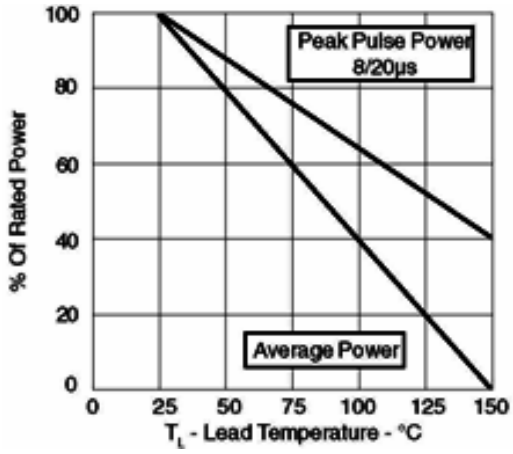

Figure 3. Power Derating Curve

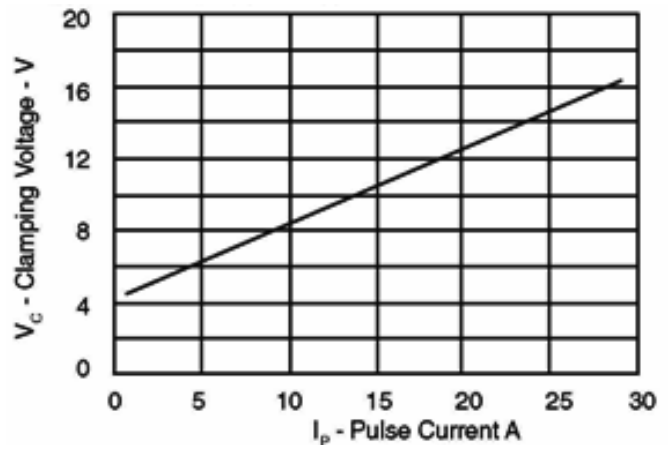
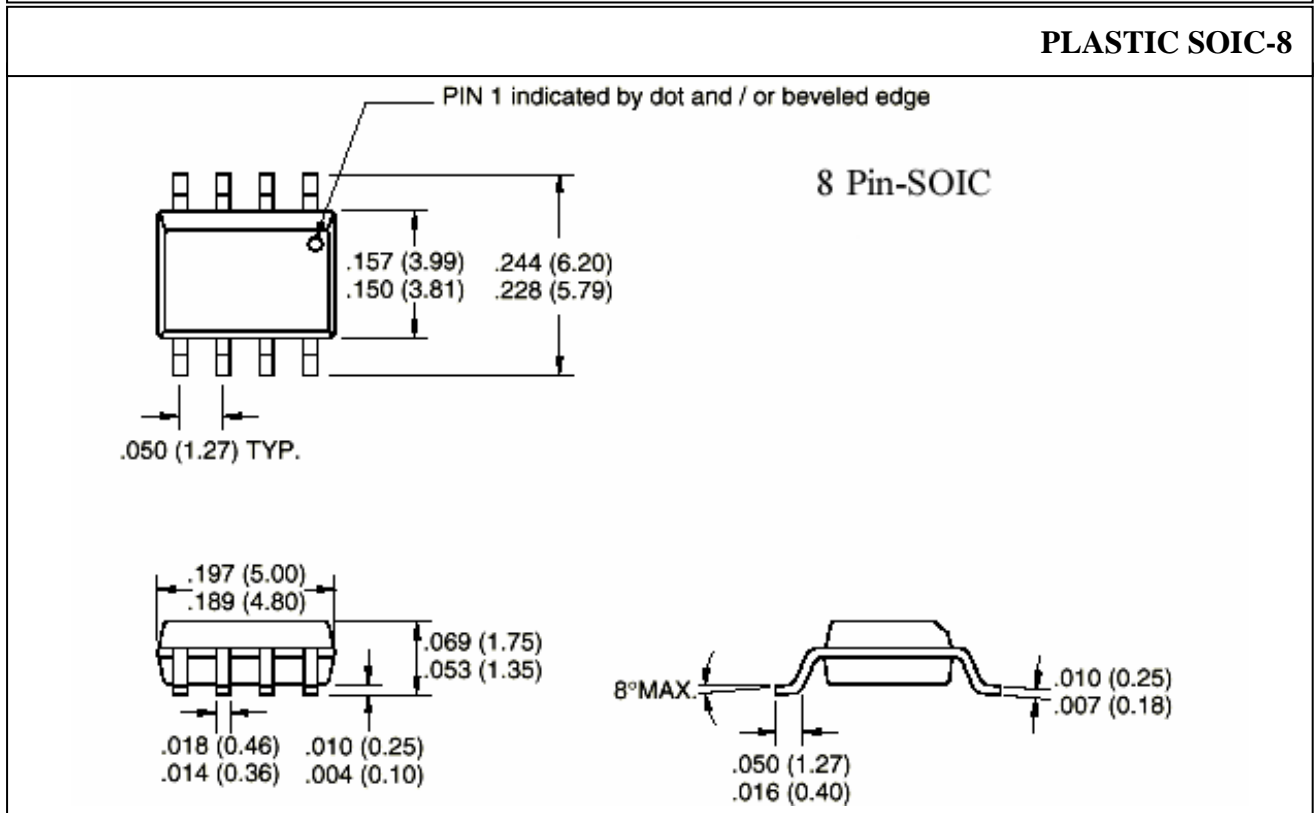
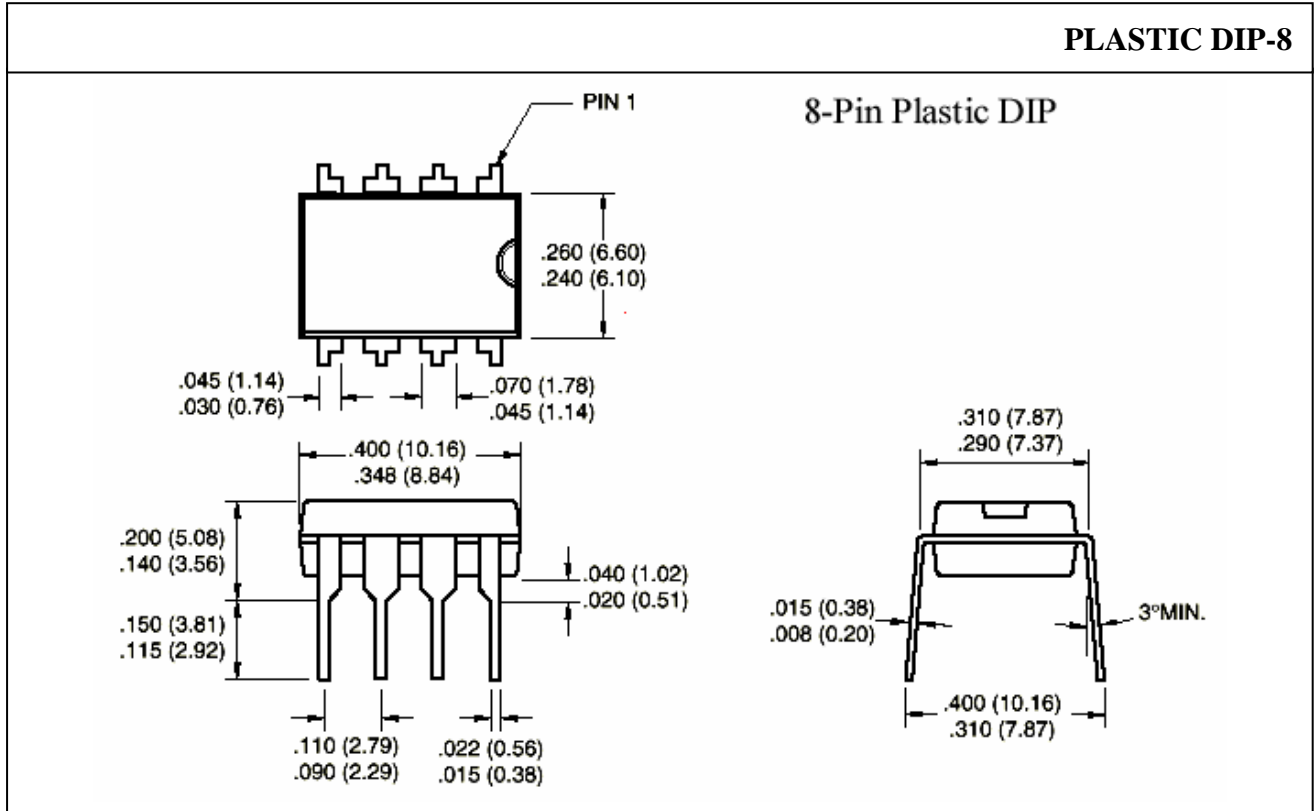

Figure 4. Typical Clamping Voltage vs Peak Pulse Current

PACKAGE DIMENSIONS



APPLICATION NOTES

To select appropriate Transient Voltage Suppressor (TVS) part, a designer first of all should pay attention on the parameter “stand off voltage V_{WM} “. The peak operating voltage must be less or equal to the stand of voltage of selected part.

The using of TVS product is especially important for the electronic equipment that can be affected and damaged by Electro Static Discharge (ESD), Electrical Fast Transient and lightning effects. The MN0284 was specially designed to provide appropriate level of protection for sensitive equipment. The part meets and exceeds the requirements of the standards IEC 61000-4-2 and IEC64000-4-4.

Bidirectional two line common mode

Two lines can be protected in the bidirectional common mode by utilizing the MN0284 product. Devices are connected in an anti-parallel configuration between line and ground. Pins 1 and 8 are connected to line (or ground) while the pin pair 2 and 7 is connected to the ground (or line). Note that product can be connected in either configuration. For protecting the second line in the bidirectional common mode Pins 4 and 5 are connected to line 2 (or ground) while the pin pair 3 and 6 are connected to the ground (or line). Note that product can be connected in either configuration.

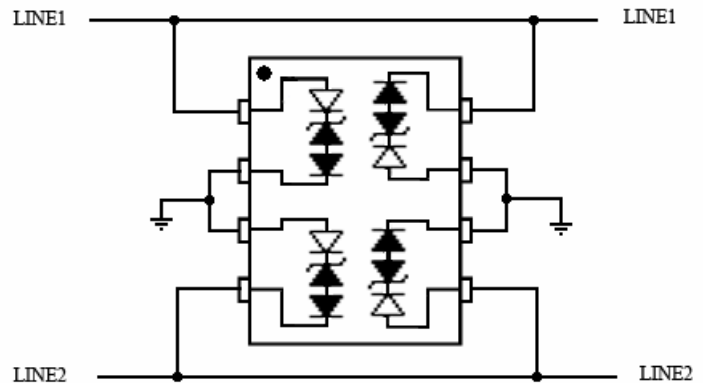

Figure 5. Common Mode Configuration

Bidirectional two line pair differential mode

Two line pairs can be protected in the differential mode by utilizing the MN0284 product. The device circuits are connected in an anti-parallel configuration between line 1 and line 2 of the Line Pair to be protected.

For protecting Line Pair #1, pins 1 and 8 are connected to line 2 and pin 2 and 7 are connected to line 1 of the line pair.

For protecting Line Pair #2 in the bidirectional-differential mode, connect pins 4 and 5 to line 1 and pins 3 and 6 to line 2 of Line Pair #2

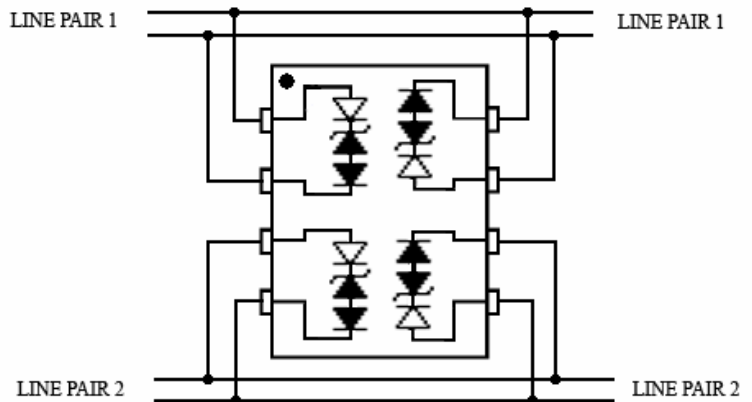

Figure 6. Differential Mode Configuration

CIRCUIT BOARD LAYOUT RECOMMENDATIONS

Circuit board layout is critical for Electromagnetic Compatibility (EMC) protection. The following guidelines are recommended:

- The protection device should be placed near the input terminals or connectors, the device will divert the transient current immediately before it can be coupled into the nearby traces.
- The path length between the TVS device and the protected line should be minimized.
- All conductive loops including power and ground loops should be minimized.
- The transient current return path to ground should be kept as short as possible to reduce parasitic inductance.
- Ground planes should be used whenever possible. For multilayer PCBs, use ground vias.